

## Falcon F150 High Lift Rear Load



Designed for high lift applications such as warehousing and rack storage. The Falcon F150 HighLift Automatic Guided Vehicle utilizes a hydraulic mast capable of reaching heights of up to 24 feet. The Falcon F150 AGV requires only a minimum amount of maintenance to keep it clean and looking new.

A bidirectional single drive unit allows for a great deal of flexibility in movement and speed. The single wheel suspension keeps the drive wheel in contact with the floor at all times. All wheels feature extra thick polyurethane tread for long life and quiet operation. Electromechanical brakes are included as an integral part of the permanent magnet motor and sealed gearbox assembly. Each Falcon F150 is equipped with a 48-volt battery power source, which is sized for more than a full shift of operation. Vehicle object detection sensors reduce vehicle speed and stop vehicle travel when an obstruction is in the travel path of the vehicle.

### Features

- ▶ Swing Out Cabinet Design Provides Easy Access to the Drive Assembly and All Electrical Components.
- ▶ Complete Travel Drive Assembly is Easily Removed by removing 4 bolts without Lifting the AGV.
- ▶ Vertical Travel Drive Design Provides Easy Access to the Drive Components.
- ▶ Travel Drive Gearbox Gears are Hardened, Precision Ground, with Oil Bath Lubrication for Long Life and Quiet Operation.
- ▶ Idle Wheels have "Sealed for Life" Bearings and Hardened Axle Shafts.
- ▶ Oil Bath Lubrication is used in Travel Gearbox.
- ▶ AGV Frame is of Welded Construction Using Heavy Wall Structural Tubing, which Provides High Bending and Torsion Strength and Stiffness.
- ▶ Corecon's Modular Control System separates AGV Functions, making Problem Diagnosis Quicker and Reduces AGV Downtime.

### Benefits

- ▶ Long Life Design (15+ Years of Life)
- ▶ Low Cost of Ownership
- ▶ Low Maintenance
- ▶ Speedy & Easy Access to All Major AGV Components
- ▶ Modular Design for Faster Diagnosis & Quick Repair
- ▶ Large Diameter Wheels for efficient operation and long life
- ▶ Opportunity Charging System Eliminates Battery Handling
- ▶ Simple AGV Deployment
- ▶ Variety of Tooling Available for Many Falcon AGV Applications

### AGV Options

- ▶ Fork Tip Sensors
- ▶ Tilting Forks
- ▶ Shifting Forks
- ▶ Fork Side Shifter
- ▶ Extending Forks
- ▶ Leveling Forks
- ▶ Load Scale
- ▶ Bar Code Reader
- ▶ Optical Communication
- ▶ Radio Communication
- ▶ Sealed Batteries
- ▶ Fast Charge Batteries
- ▶ Quick Charge Batteries
- ▶ Brushless Motors
- ▶ Laser Bumper with Software Selection Zones

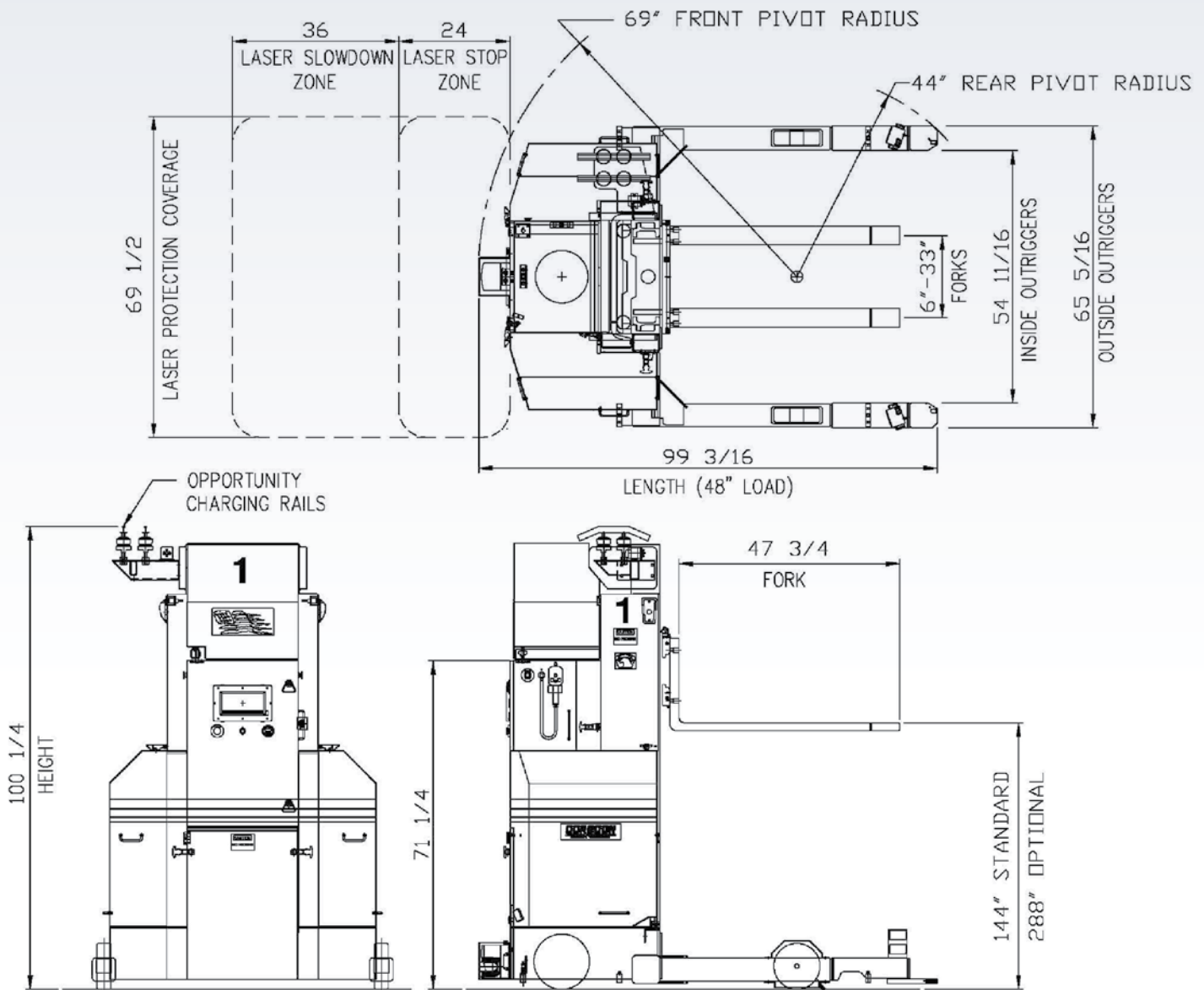

## Performance

Speed Forward:	220 ft./Min.Max
Speed Reverse:	110 ft./Min
Acceleration & Deceleration:	0-220 ft./Min = 3 Sec. in 5ft.
Rotate Vehicle 90 Degrees:	12 Sec.
Stopping and Repetitive Stopping Accuracy:	+/- 3/8 "
Minimum Cornering Radius:	36"
Fork Lifting Speed:	30ft/min.
Lifting Capacities @ 24" Load Center of Gravity	4,000 & 6,000 Lbs.
Battery Capacity (Standard):	375 Amp/Hr.

## Size / Weight

Overall Length:	99.2"
Overall Width:	65.3"
Overall Height:	100.2"
Service Weight:	6,000 Lbs.

## Forks

Width:	4"
Length:	47.8"
Centers:	6" to 33"
Lift Height:	144"
Lift Height Option:	288"
Lift Accuracy:	+/- 1/8"

